

12ft Alfablok®

HEIGHT	WIDTH	THICKNESS	WEIGHT
12'-0"	4'-0"	4'-0" at base	6400 lbs.

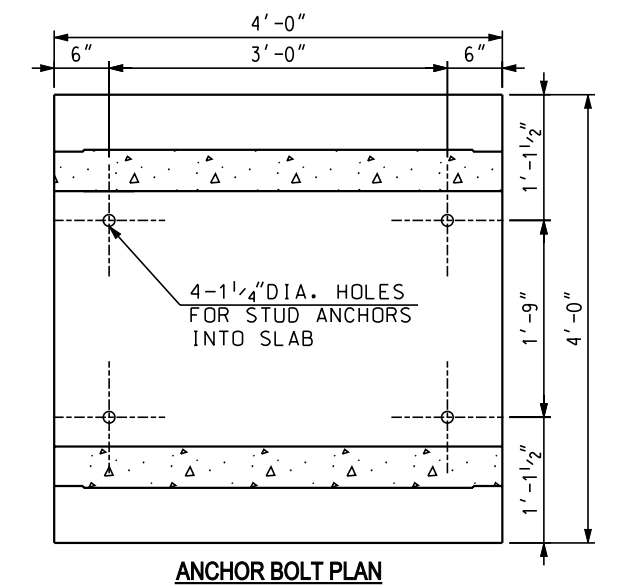
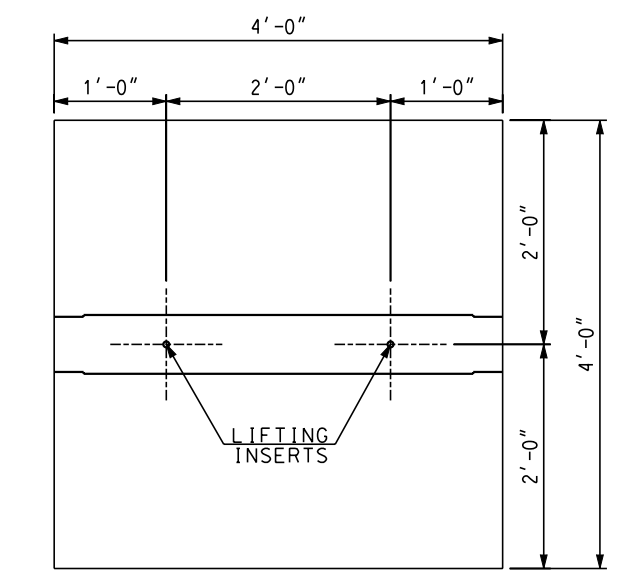
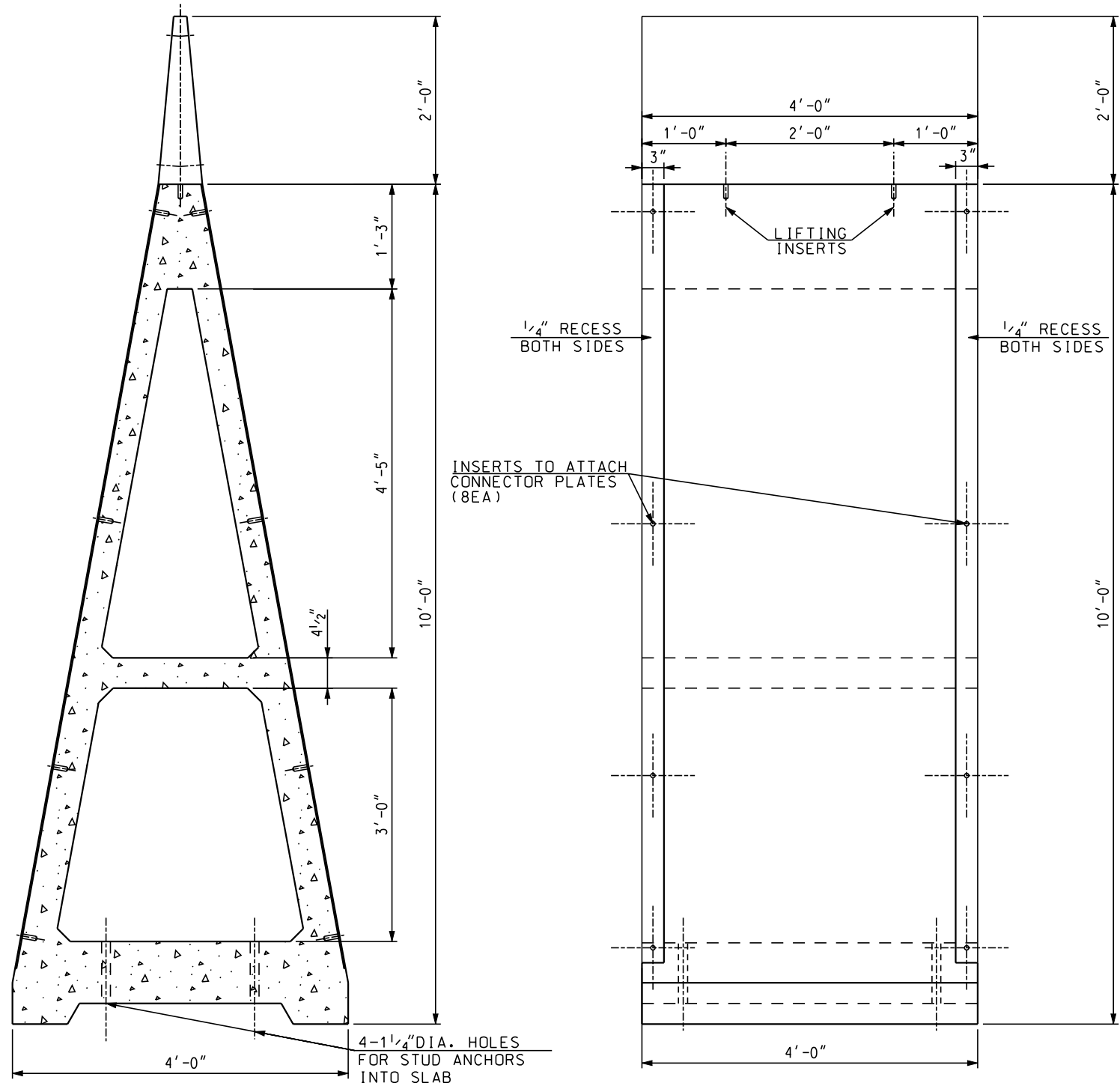
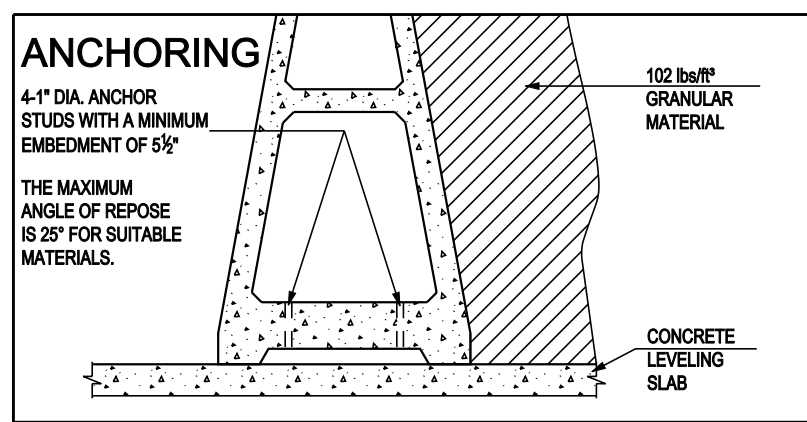
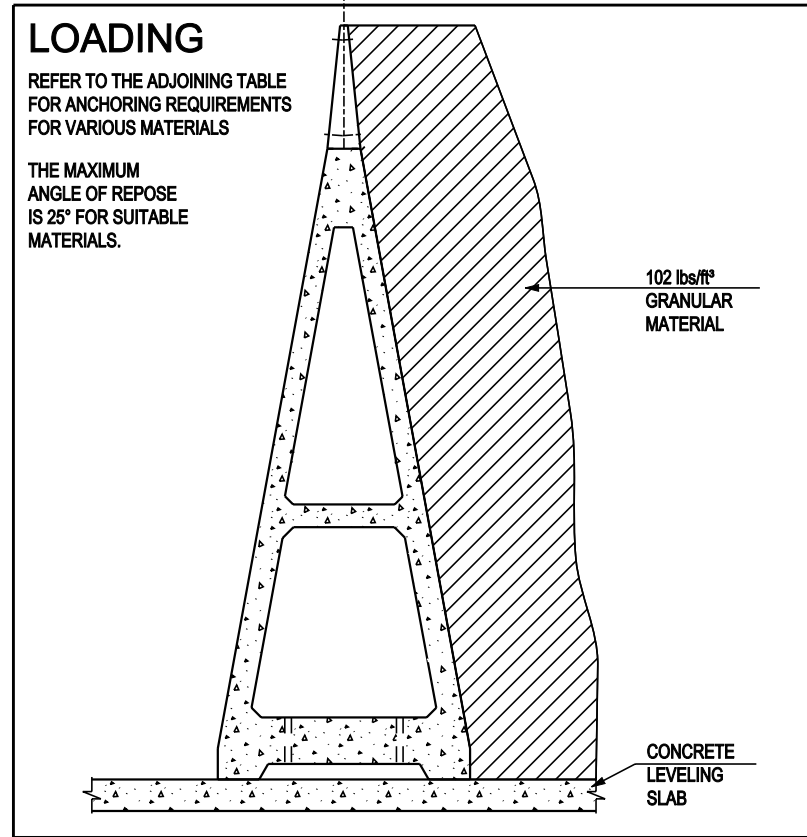
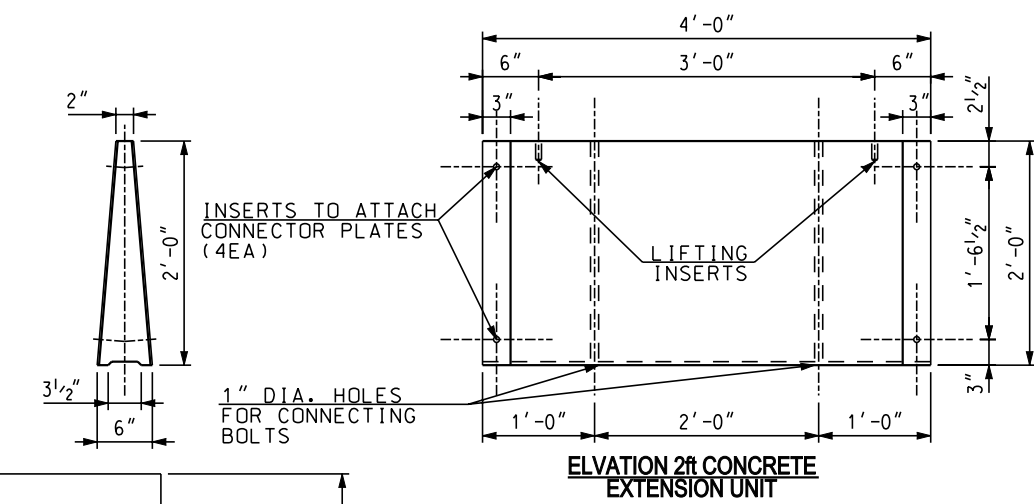
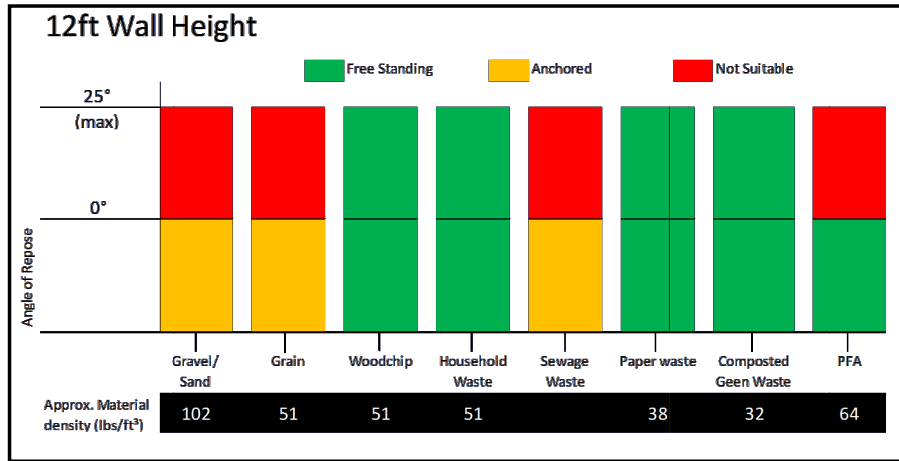

Tricon Precast Limited™

15055 HENRY ROAD
HOUSTON, TEXAS, 77060
(281) 931-9832
(281) 931-0061
www.triconprecast.com

TEC TRICON ENGINEERING GROUP, LTD
A Tricon Precast Company

1009 44th STREET, SUITE A-2
WYOMING, MI 48509
PH. (616) 261-8630